

RETAINING WALL CROSS SECTIONS

PARKWALL

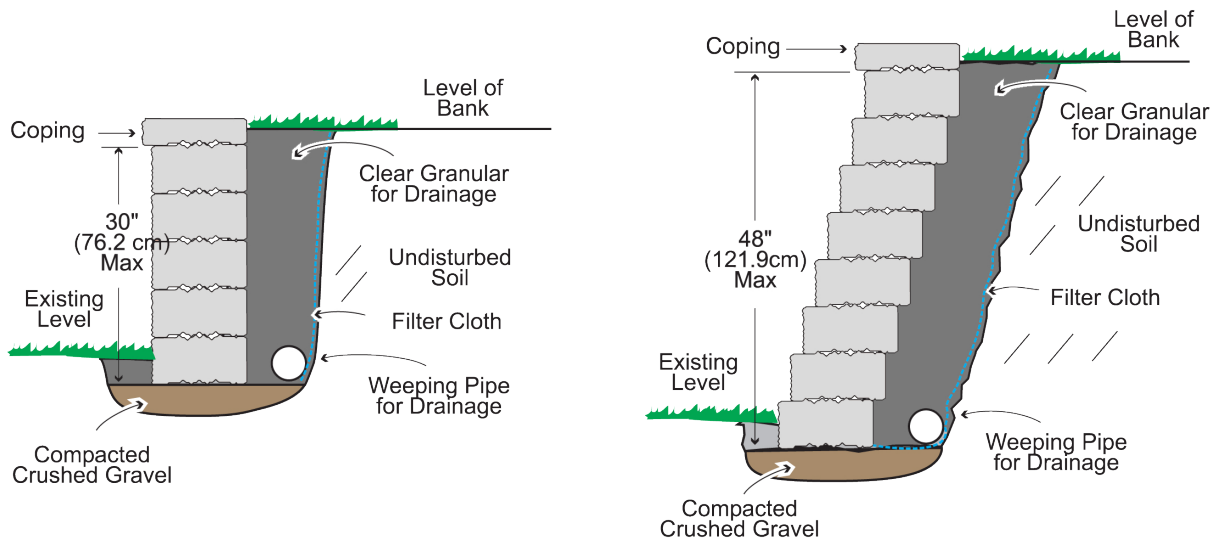

DESIGN VERSATILITY



No block manipulation required. Simply turn the block, or set in and out as desired along the patented locking feature.

GARDEN LOCK

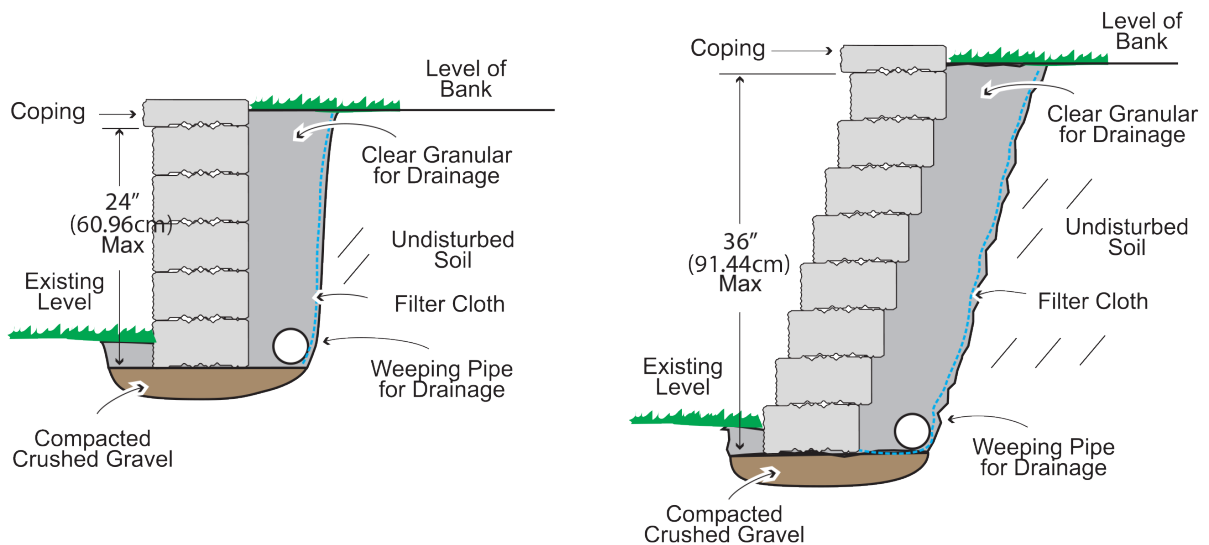

IKON

VERTICAL

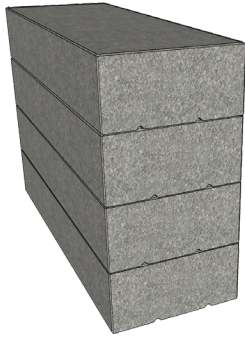

Alternate the direction of units each row. Off-set locking feature align to create vertical finish.

30MM OFF-SET

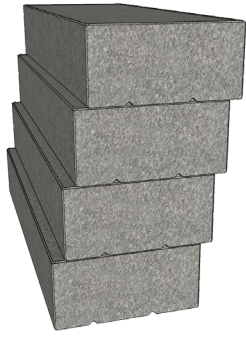

Install units in the same direction. Off-set locking feature creates a 30mm set back.

30MM CUSTOMIZED OFF-SET

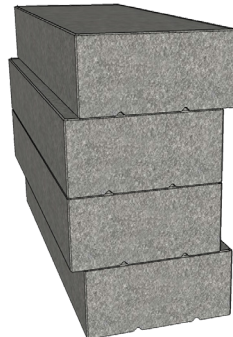

Manipulate the direction of units at desired rows. Off-set locking feature allows for customized design and finish.

Off-Set Locking System

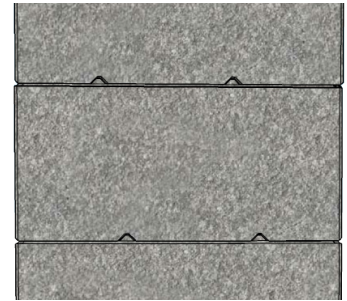

BARNBEAM

1/2 OFF-SET

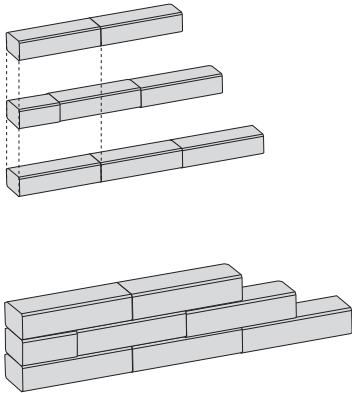

Create 1/2 unit (20" w) to start alternating rows.

TYPICAL CROSS SECTIONS

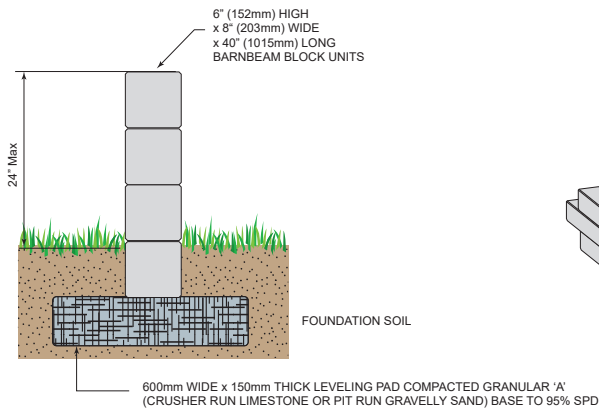

CORNER CONSTRUCTION

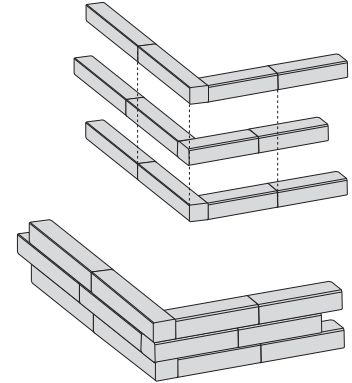

Alternate overlap each row.

ARLINGTON / HAZELTON

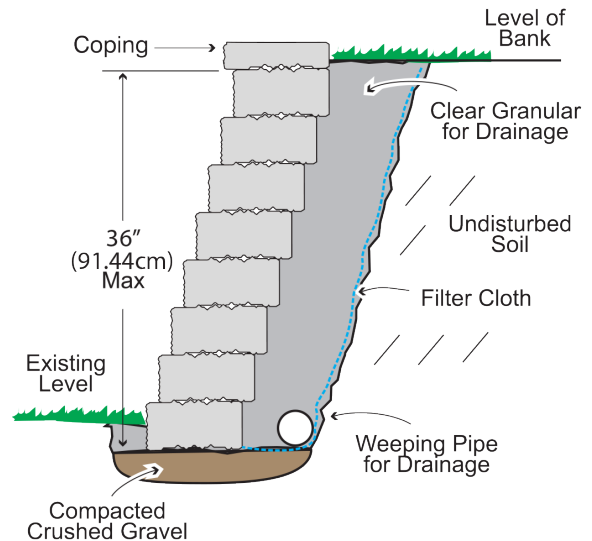
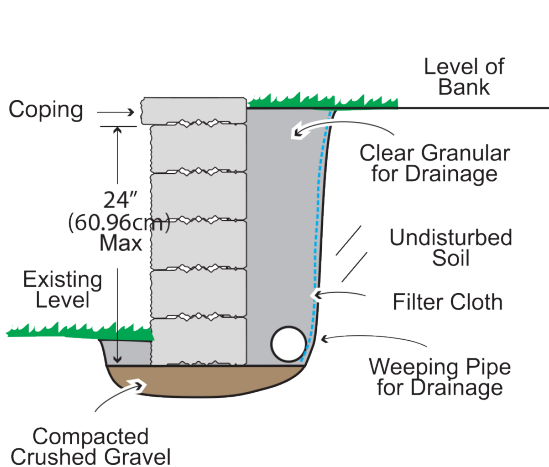

RIDGEWALL

TYPICAL CORNER CONSTRUCTION

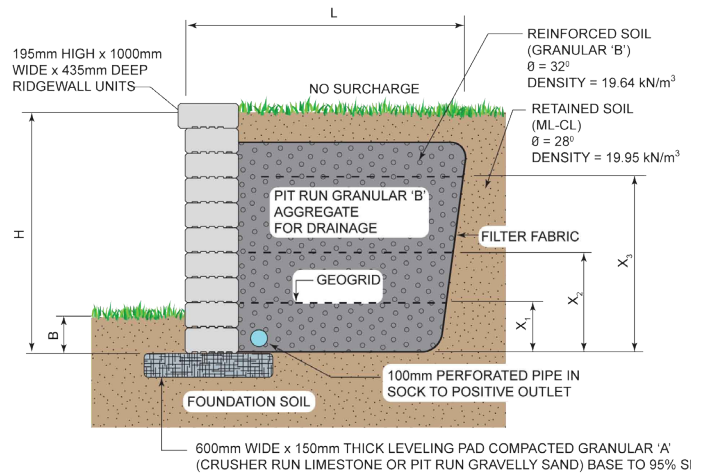
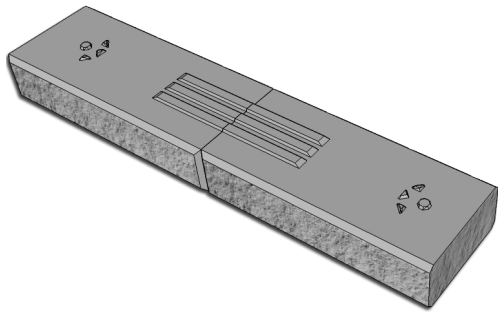

GEOGRID REINFORCED RIDGEWALL CROSS SECTION WITH LEVEL BACKFILL AND NO SURCHARGE

Ridge-to-Ridge & Key-to-Key Installation (Best Practice where possible)

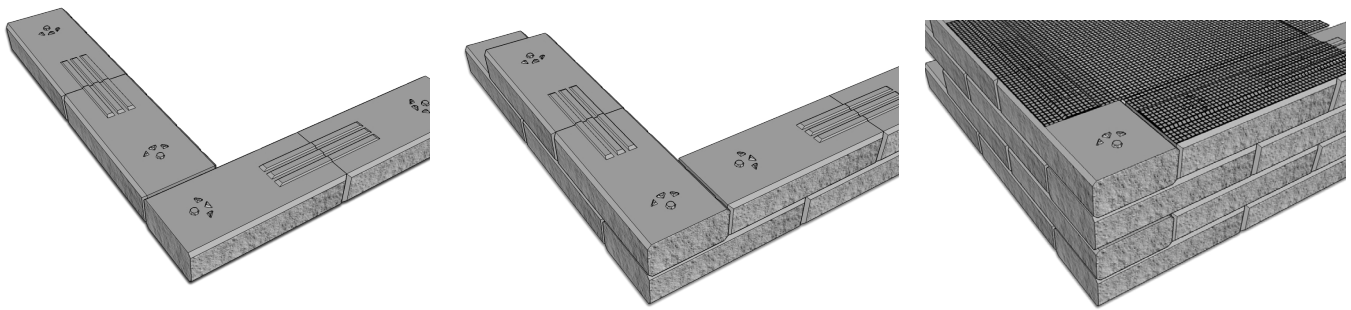

90 Corner - Row 1 & 2 (Continue same sequence for following rows) + typical grid placement

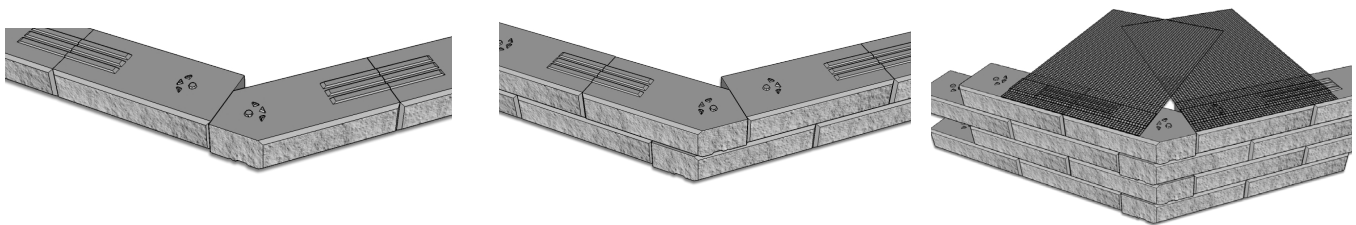

45 Corner - Row 1 & 2 (Continue same sequence for following rows) + typical grid placement

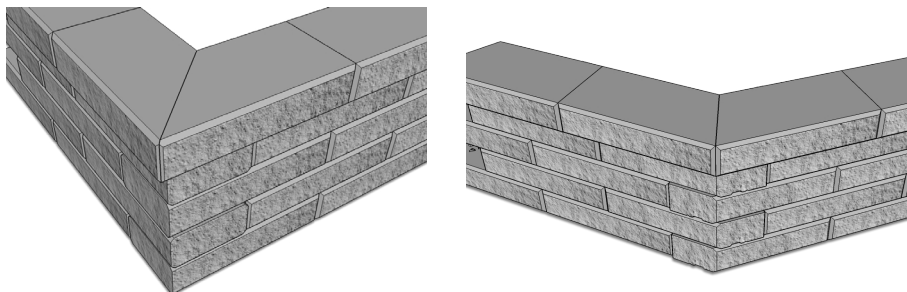

Ridge & Key System

